

## 2.3 cu. ft. Compact All-in-One Washer & Dryer Combo

- Compact All-In-One Washer/Dryer Combination
- Ventless Condensing Drying
- 2.3 cu. ft. Capacity
- TurboWash® Technology
- Steam Technology & Allergiene™ Cycle
- 14 Cycles / 9 Options
- Internal Heater
- ColdWash™ Option
- Direct Drive Motor (10-Year Limited Warranty)
- NeverRust™ Stainless Steel Drum
- LG ThinQ® Technology (Wi-Fi)



### COLOR AVAILABILITY

- WM3499HVA – Graphite Steel

### CAPACITY & MATCHING DRYERS

|                         |     |
|-------------------------|-----|
| Capacity (cu. ft.)      | 2.3 |
| Matching Electric Dryer | N/A |
| Matching Gas Dryer      | N/A |

### APPEARANCE

|                                      |     |
|--------------------------------------|-----|
| Electronic Controls with LED Display | Yes |
| Hard Buttons                         | Yes |
| Touch Buttons                        | Yes |
| Dial-A-Cycle™                        | Yes |

### ENERGY & WATER

|  |     |
|--|-----|
| ENERGY STAR® Qualified                   | No  |
| CEE Qualified                            | No  |
| Integrated Modified Energy Factor (IMEF) | 2.0 |
| Integrated Water Factor (IWF)            | 6.0 |

### CYCLES

|                  |  |
|------------------|--|
| Number of Cycles | 14   |
| Wash Cycles      | Normal, Bulky/Large, Baby Wear, Perm. Press, Delicates, Hand Wash/Wool, Quick Wash, Tub Clean, Sanitary, Heavy Duty, Drain+Spin, Wash+Dry, Allergiene™, Downloaded |

### OPTIONS

|                   |   |
|-------------------|---|
| Number of Options | 9   |
| Options           | Prewash, *Wi-Fi, Delay Wash (Time Delay), Steam, *Heavy soil, Child Lock, *Signal, Add Garment, Timed Dry |

### WASH DETAILS

|                            |  |
|----------------------------|--|
| Internal Heater            | Yes  |
| Number of Wash/Rinse Temps | 5  |
| Wash/Rinse Temps           | Extra Hot, Hot, Warm, Cold, Tap Cold (All Cold Rinses) |
| Number of Spin Speeds      | 5  |
| Spin Speeds                | Extra High, High, Medium, Low, No Spin                 |
| Max RPM                    | 1,400  |
| Water Levels               | Load Sensing   |
| Number of Soil Levels      | 2  |
| AAFA Certified             | Yes  |

### DRY DETAILS

|                            |  |
|----------------------------|--|
| Ventless Condensing Drying | Yes  |
| Automatic Dry Cycles       | More Dry, Normal Dry, Damp Dry, Low Temp Dry |
| Time Drying                | 120 min, 60 min, 30 min                      |
| Normal Drying              | Yes  |
| Turbo Drying               | No   |

### FABRIC CARE

|                    |                |
|--------------------|----------------|
| AI DD™             | No             |
| Wash Technology    | TurboWash® 2.0 |
| Steam Technology   | Yes            |
| Allergiene™ Cycle  | Yes            |
| Sanitary Cycle     | Yes            |
| ColdWash™ Option   | Yes            |
| SenseClean™ System | Yes            |

### CONVENIENCE

|                                    |   |
|------------------------------------|---|
| TrueBalance™ Anti-Vibration System | Yes   |
| Dispenser Type                     | 3-Tray (Main Wash Detergent, Liquid Fabric Softener, Prewash Detergent) |
| LoDecibel™ Quiet Operation         | Yes   |

## CONVENIENCE CONTINUED

|                            |     |
|----------------------------|-----|
| End of Cycle Signal        | Yes |
| LoadSense                  | Yes |
| Child Lock                 | Yes |
| Auto Suds Removal          | Yes |
| 4 Adjustable Leveling Legs | Yes |
| Easy Loading TilTub™       | Yes |
| ADA Compliant              | No  |

## SMART FEATURES

|                                |                                |
|--------------------------------|--------------------------------|
| Wi-Fi Enabled                  | Yes                            |
| ThinQ®                         | Yes                            |
| Proactive Customer Care        | No                             |
| Voice Control                  | Google Assistant, Amazon Alexa |
| SmartDiagnosis™                | Yes                            |
| Remote Start and Cycle Monitor | Yes                            |
| NFC Tag On Technology          | Yes                            |

## MOTOR AND AGITATOR

|            |                             |
|------------|-----------------------------|
| Motor Type | Inverter Direct Drive Motor |
| Axis       | Horizontal                  |

## MATERIALS AND FINISHES

|                                |                          |
|--------------------------------|--------------------------|
| NeveRust™ Stainless Steel Drum | Yes                      |
| Door / Rim                     | Glass / Chrome           |
| Door Cover                     | Black Tinted Round Cover |

## TECHNICAL SPECS

|                            |                                 |
|----------------------------|---------------------------------|
| Electrical Requirements    | 120V, 60 Hz, 10 Amps            |
| Type                       | Electric                        |
| Power Outlet Location      | Within 60" of Either Side       |
| Plug Type                  | 3-Prong (Cord Attached to Unit) |
| Min. / Max. Water Pressure | 20 - 120 psi                    |

## INCLUDED ACCESSORIES

Drain Hose, Hot/Cold Water Hoses, Non-skid Pads, Caps for covering shipping bolt holes, Wrench, Tie Strap, Elbow Bracket for Drain Hose.

## OPTIONAL ACCESSORIES

|                              |               |
|------------------------------|---------------|
| Pedestal                     | N/A           |
| LG Sidekick™ Pedestal Washer | N/A           |
| Stacking Kit                 | Not Stackable |

## DIMENSIONS

|                                   |                              |
|-----------------------------------|------------------------------|
| Product (W x H x D)               | 24" x 33 1/2" x 25 1/4"      |
| Depth with Door Open              | 45"                          |
| Carton Dimensions (W x H x D)     | 26 5/32" x 34 1/2" x 27 7/8" |
| Approx. Weight (Product / Carton) | 156.5 lbs. / 165.3 lbs.      |

## LIMITED WARRANTY

|                    |                       |
|--------------------|-----------------------|
| Parts and Labor    | 1 Year                |
| Direct Drive Motor | 10 Years (Parts Only) |
| Drum               | Lifetime (Parts Only) |

## DIMENSIONS / CLEARANCES

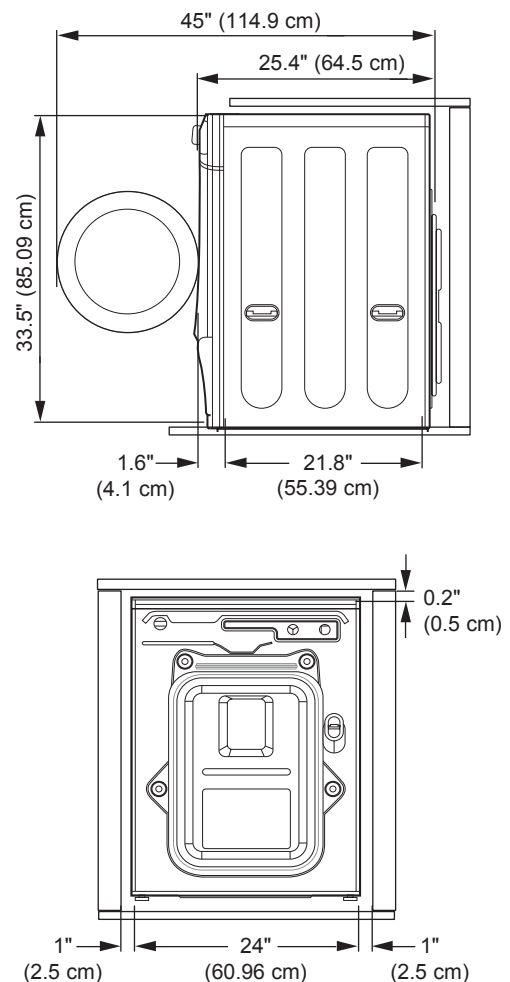

## INSTALLATION

- To ensure sufficient clearance for water lines, the drain line and airflow, allow minimum clearances of at least 1 inch (2.5 cm) at the sides. Be sure to allow for wall, door, or floor moldings that may increase the required clearances.
- Install the washing machine on a solid floor that is strong and rigid enough to support the weight of the washing machine, even when fully loaded, without flexing or bouncing. If the floor has too much flex, you may need to reinforce it to make it more rigid. If the floor is not solid, it may cause severe vibration and noise.